

MODEL 21-80/30G

Special Water Feature Pump



Features

- This high volume, low head pump comes complete with our unique mechanical shaft seal that allows the pump, if mistreated, to run dry for up to one hour.
- The pump can be used for pool water with a salt concentration of up to 5000 ppm.
- Pump parts are made of 100% recyclable plastic. Non-corrosive, chemical/UV resistant, and can withstand temperatures of up to 175° F.
- Equipped with 4" quick disconnect unions for easy installation and maintenance.
- For pool users' safety, the impeller has a dielectric shaft sleeve that provides absolute separation between pool water and electric parts.
- Heavy duty "1081" E-plus®/extreme-E™ energy efficient motors for extra low energy consumption. This large 56 frame motor is thermally protected, has a PSC switchless design and extra large sealed ball bearings.
- Motor is easy to remove without disturbing the plumbing. Reusable o-rings throughout.
- Two year warranty on the motor and all pump parts, including normal wear of the mechanical seal.
- Every pump is performance tested before leaving the Speck factory.



Model 21-80/30G



Applications

- Pools with vanishing edge, waterfall, fountain or water slide features

Dimensional Drawing

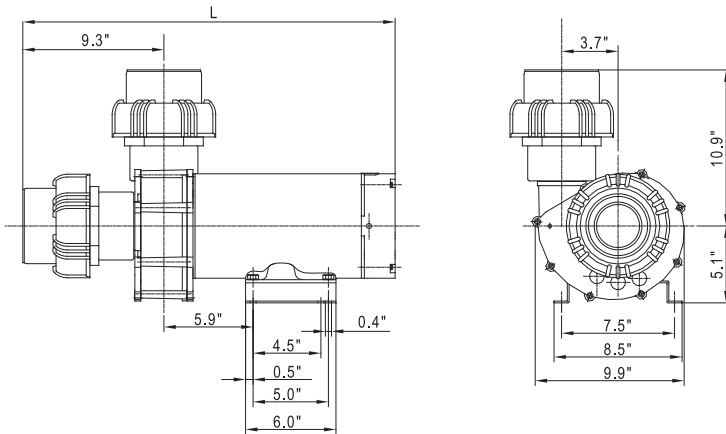

MODEL	DIMENSION "L"	SHIPPING WEIGHT
21-80/30 G	24.5"	52 lbs.

Performance Curves

