

MODEL 94

Swimming Pool Pump



Features

- This high performance pump comes complete with our unique mechanical shaft seal that allows the pump, if mistreated, to run dry for up to one hour.
- The pump can be used for pool water with a salt concentration of up to 5000 ppm.
- Quiet and efficient medium to high head pressure at a large flow rates.
- Large one-piece housing design with integrated strainer basket and easy on/off two piece lid.
- Suction and discharge are equipped with 3" quick disconnect unions for easy installation and maintenance.
- Wrench for unions and lid is included with each pump.
- Available with a heavy duty energy efficient totally enclosed fan cooled (TEFC) or Open Drip Proof (ODP) motor designs. (*Model 94-IX requires a motor starter.*)
- Motor is easy to remove without disturbing the plumbing. Reusable o-rings throughout.
- Two year warranty on the motor and all pump parts, including normal wear of the mechanical seal.
- Every pump is performance tested before leaving the Speck factory.



Model 94-IX

Applications

- Large residential & small commercial pools
- Filter Applications
- Water Features

Dimensional Drawing

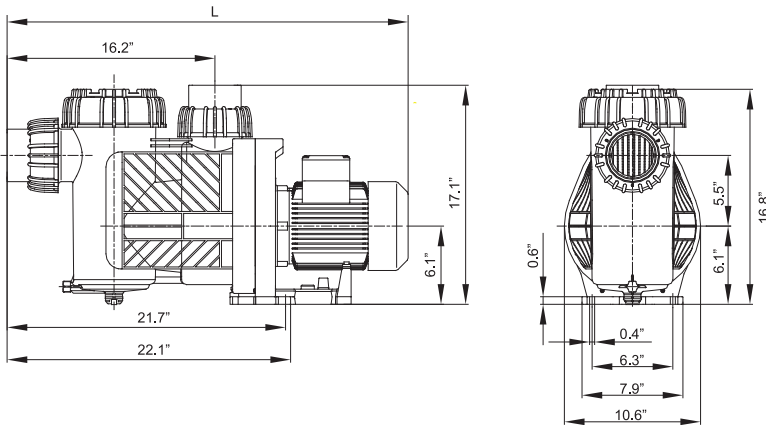

MODEL	DIMENSION "L"	SHIPPING WEIGHT
94-VIII	35.5"	75 lbs.
94-IX	33.0"	104 lbs.

Performance Curves

