

**DG-FA-15.15.46-ABS Degassing Column**

- Flow Rate: 10-20
- Dimensions: 15" x 15"
- Height: 46"
- Media: Random Packed Bed
- Water Outlet: Open Channel OR 2" Sch 40 PVC
- Water Inlet: 1.5" Sch 40 PVC
- Air Inlet: 1" Sch 40 PVC
- Air Outlet: 1.5" Sch 40 PVC
- Voltage-Air Pump: 115
- FLA-Blower: 1.3

\* COPYRIGHT \*  
These drawings including design idea and construction techniques herein are the sole property of Oceans Design Inc. They shall not be revised, copied, or reproduced in any manner without the written consent of Oceans Design Inc.

PROJECT		DG-FA-15.15.46-ABS		SHEET TITLE	
DESCRIPTION		15" x 15" x 46" Forced Air Degassing Column ABS Plastic		DG-FA-15.15.46-ABS	
DRAWN BY	DATE	REVISION	SCALE	SHEET #	
MP	9/2/2019	REV A	1:20	1 OF 2	

**OCEANS**  
DESIGN  
740 Wooten RD STE 104  
Colorado Springs, CO 80915

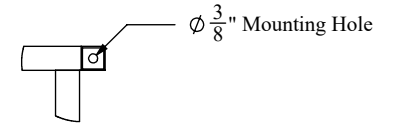
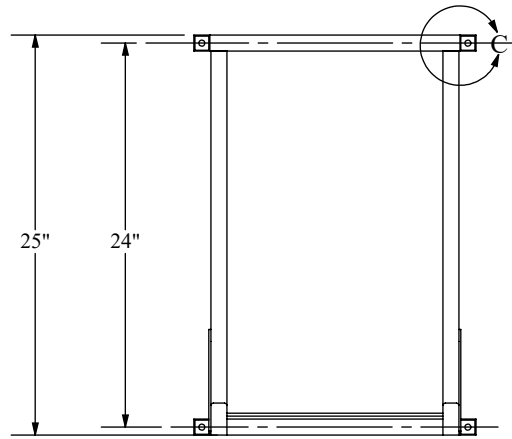
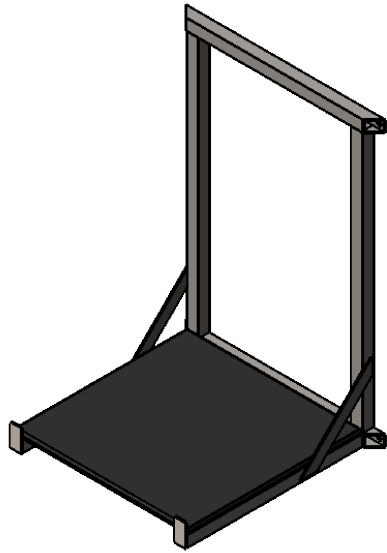

DETAIL C  
SCALE 1 : 8

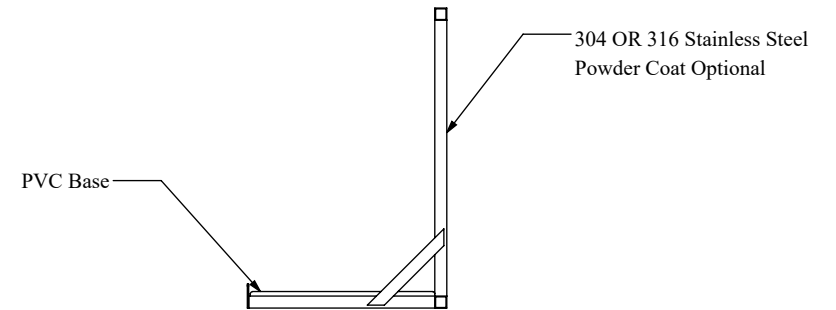
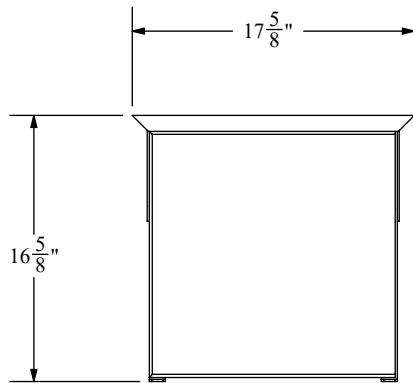

**OCEANS**  
DESIGN  
740 Wooten RD STE 104  
Colorado Springs, CO 80915

\* COPYRIGHT \*  
These drawings including design idea and construction techniques herein are the sole property of Oceans Design Inc. They shall not be revised, copied, or reproduced in any manner without the written consent of Oceans Design Inc.

<b>PROJECT</b>	RACK-DG-FA-15.15.46-ABS		
<b>DESCRIPTION</b>	Stainless Steel Wall Mount Rack for 15" x 15" x 46" Degassing Column		
<b>DRAWN BY</b>	<b>DATE</b>	<b>REVISION</b>	<b>SCALE</b>
MP	9/2/2019	REV A	1:20

<b>SHEET TITLE</b>	Wall Mount Rack
<b>SHEET #</b>	2 OF 2